

# **SERVO ELECTROMECHANIC ACTUATOR**



**60 Kips ELECTRO-MECHANICAL ACTUATOR  
USER MANUAL**

## Proprietary Rights Notice

This document and the information that it contains are the property of Teknik Destek Grubu Company (TDG). Rights to duplicate or otherwise copy this document and rights to disclose the document and the information that it contains to others and the right to use the information contained therein may be acquired only by written permission signed by a duly authorized officer of TDG.

## Trademarks

TDG-Servo Solutions is a registered trademark of Teknik Destek Grubu Company (TDG). Other names, logos, icons and marks identifying TDG Servo products and services referenced therein are trademarks of TDG and may not be used without the prior written permission of TDG.

## Original Instructions

© Copyright 2019 Teknik Destek Grubu Company. All rights reserved.  
All the specifications shown in this document are subject to change without notice.

## Teknik Destek Grubu Headquarters

ODTÜ Teknokent Bilişim İnovasyon Merkezi  
Mustafa Kemal Mahallesi Dumlupınar Bulvarı No:280G /214  
06530 Çankaya/Ankara/TURKİYE  
+90 (312) 473 97 91  
[info@tdg.com.tr](mailto:info@tdg.com.tr)  
[tdg.com.tr](http://tdg.com.tr)

## General Safety Precautions



Force testing systems are potentially hazardous.

Static loading involves inherent hazards from high forces, rapid motions, and stored energy. You must be aware of all the moving and operating components in the testing system that are potentially hazardous.



Carefully read all relevant manuals and observe all Warnings and Cautions. The term Warning is used where a hazard may lead to injury or death. The term Caution is used where a hazard may lead to damage to equipment or to loss of data.

Because of the wide range of applications with which our instruments are used, and over which we have no control, additional protection devices and operating procedures may be necessary due to specific accident prevention regulations, safety regulations, further EEA directives or locally valid regulations. The extent of our delivery regarding protective devices is defined in your initial sales quotation. We are thus free of liability in this respect.

At your request, we will gladly provide advice and quotations for additional safety devices such as protective shielding, warning signs or methods of restricting access to the equipment.

The following pages detail various general warnings that you must always heed while using materials testing equipment. You will find more specific Warnings and Cautions in the text whenever a potential hazard exists.

Your best safety precautions are to gain a thorough understanding of the equipment by reading your instruction manuals and to always use good judgement.

It is our strong recommendation that you should carry out your own safety risk assessment on the use of the test system, test methods employed, specimen loading and specimen behavior at failure.

## WARNINGS



### **Crush Hazard - Allow only one person to always handle or operate the system.**

Operator injury may result if more than one person operates the system. Before working inside the hazard area between the swivels and the specimen, ensure that no other personnel can operate the computer or any of the system controls. When the test is started, ensure that no one is inside the working space.



### **Crush Hazard - Take care when installing or removing a specimen, assembly, structure, or load string component.**

Installation or removal of a specimen, assembly, structure, or load string component involves working inside the hazard area between actuator stroke and test specimen. Keep clear of the hazard area during actuator movement. Ensure that all actuator movements necessary for installation or removal are slow and, where possible, at a low force setting.



### **Hazard - Press the Emergency Stop button whenever you consider that an unsafe condition exists.**

The Emergency Stop button removes hydraulic power or electrical drive from the testing system and brings the hazardous elements of the system to a stop as quickly as possible. It does not isolate the system from electrical power, other means are provided to disconnect the electrical supply. Whenever you consider that safety may be compromised, stop the test using the Emergency Stop button. Investigate and resolve the situation that caused the use of the Emergency Stop button before you reset it.



### **Flying Debris Hazard - Make sure that test specimens are installed correctly in grips or fixtures to eliminate stresses that can cause breakage of grip jaws or fixture components.**

Incorrect installation of test specimens creates stress in swivel and the mechanical transmission system and can result in breakage of these components. The high energy involved can cause the broken parts to be projected forcefully some distance from the test area. Install specimens in the center of the swivel jaws in line with the load path.



### **Hazard - Protect electrical cables from damage and inadvertent disconnection.**

The loss of controlling and feedback signals that can result from a disconnected or damaged cable causes an open loop condition that may drive the actuator or crosshead rapidly to its extremes of motion. Protect all electrical cables, particularly transducer cables, from damage. Never route cables across the floor without protection, nor suspend cables overhead under excessive strain. Use padding to avoid chafing where cables are routed around corners or through wall openings.



**High/Low Temperature Hazard - Wear protective clothing when handling equipment at extremes of temperature.**

Materials testing is often carried out at non-ambient temperatures using ovens, furnaces or cryogenic chambers. Extreme temperature means an operating temperature exceeding 60 °C (140 °F). You must use protective clothing, such as gloves, when handling equipment at these temperatures. Display a warning notice concerning low or high temperature operation whenever temperature control equipment is in use.

You should note that the hazard from extreme temperature can extend beyond the immediate area of the test.



**Hazard - Do not place a testing system off-line from computer control without first ensuring that no actuator or crosshead movement will occur upon transfer to manual control.**

The actuator or crosshead will immediately respond to manual control settings when the system is placed off-line from computer control. Before transferring to manual control, make sure that the control settings are such that unexpected actuator or crosshead movement cannot occur.



**Robotic Motion Hazard - Keep clear of the operating envelope of a robotic device unless the device is de-activated.**

The robot in an automated testing system presents a hazard because its movements are hard to predict. The robot can go instantly from a waiting state to high-speed operation in several axes of motion. During system operation, keep away from the operating envelope of the robot. De-activate the robot before entering the envelope for any purpose, such as reloading the specimen magazine.



**Hazard - Set the appropriate limits before performing loop tuning or running waveforms or tests.**

Operational limits are included within your testing system to suspend motion or shut off the system when upper and/or lower bounds of actuator or crosshead travel, or force or strain, are reached during testing. Correct setting of operational limits by the operator, prior to testing, will reduce the risk of damage to test article and system and associated hazard to the operator.



**Electrical Hazard - Disconnect the electrical power supply before removing the covers to electrical equipment.**

Disconnect equipment from the electrical power supply before removing any electrical safety covers or replacing fuses. Do not reconnect the power source while the covers are removed. Refit covers as soon as possible.



**Rotating Machinery Hazard - Disconnect power supplies before removing the covers to rotating machinery.**

Disconnect equipment from all power supplies before removing any cover which gives access to rotating machinery. Do not reconnect any power supply while the covers are removed unless you are specifically instructed to do so in the manual. If the equipment needs to be operated to perform maintenance tasks with the covers removed, ensure that all loose clothing, long hair, etc. is tied back. Refit covers as soon as possible.



**Explosion Hazard - Wear eye protection and use protective shields or screens whenever any possibility exists of a hazard from the failure of a specimen, assembly or structure under test.**

Wear eye protection and use protective shields or screens whenever a risk of injury to operators and observers exists from the failure of a test specimen, assembly or structure, particularly where explosive disintegration may occur. Due to the wide range of specimen materials, assemblies or structures that may be tested, any hazard resulting from the failure of a test specimen, assembly or structure is entirely the responsibility of the owner and the user of the equipment.



**Hazard - Ensure components of the load string are correctly pre-loaded to minimize the risk of fatigue failure.**

Dynamic systems, especially where load reversals through zero are occurring, are at risk of fatigue cracks developing if components of the load string are not correctly pre-loaded to one another. Apply the specified torque to all load string fasteners and the correct setting to wedge washers or spiral washers. Visually inspect highly stressed components such as grips and threaded adapters prior to every fatigue test for signs of wear or fatigue damage.

## Contents

1	Hardware .....	8
1.1	Servo Actuator.....	8
1.2	Control Box.....	10
2	Specifications and Startup.....	11
3	Test Duration and Test Type .....	11
4	Maintenance of the System .....	12
4.1	Nuts and Bolts .....	12
4.2	Dust and Cleaning.....	12
4.3	Maintenance checks before operation.....	12
4.4	Periodic Maintenance.....	13
5	Troubleshooting .....	13

# 1 Hardware

## 1.1 Servo Actuator

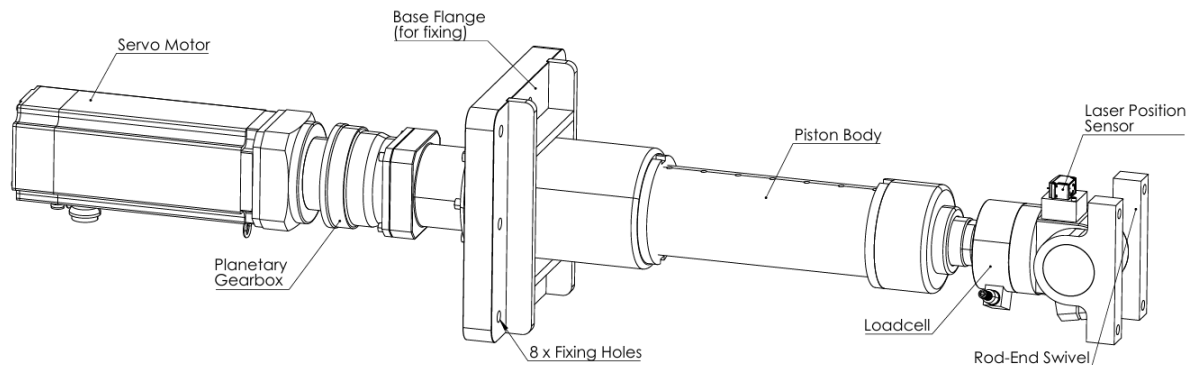

COMPONENTS	DESCRIPTION
Servo Motor and Driver	Servo driver transmits the motion signal to the servo motor with the command it receives from the controller. A gearbox is used to allow high torque operation.
Base Flange / Load Frame Mounting Support	Steel supports are specifically designed to mount the actuator on the load frame.
Laser Position Sensor	This is used to stop the actuator from moving beyond the mechanical stroke limit (forward and reverse). When either position is triggered, torque to the actuator is disabled.
Piston Body	Rigid steel body that houses the linear motion components like ball-screw, coupling and bearings.
Loadcell	Analog Loadcell allows force Control and outputs the force applied by the actuator.
Rod-End Swivel	The swivel will be used to connect the actuator to the specimen and includes spherical bearings to allow for small mounting inaccuracies and rotation.
® EasyTest CONTROL Software	EasyTest CONTROL testing software that controls the testing system, running tests and analyzing test data to produce test results.

The Actuator is driven by a Servo Motor coupled to a planetary spur gearbox to allow high force capacity at lower speeds. Ball Screw is used with special spherical bearings for force transmission to the Actuator rod. Loadcell is attached to the Rod-end of the actuator to give real-time force readings which is in turn coupled to a Swivel to allow easy mounting to the specimen.

The Servo Motor has a built-in quadrature digital encoder which provides position data in counts. This is then converted to 'mm' for the user to see real-time position of the Actuator. The Analog Loadcell provides voltage reading when force is applied by the actuator. These voltage readings are amplified and converted to force values in by the TDG built-in ADC (digitizer).

The actuator can be operated in 2 modes: 'Position Control' and 'Force Control'. Switching between the 2 modes can be done from the EasyTest Control Software. Position Control allows the user to use position data from the encoder as feedback for the PID Control loop. Force Control allows the user to use Analog output from the Loadcell as feedback for the PID Control loop. Precise displacement and

force commands can be executed by the Actuator in the form of point-to-point motion, sinusoidal motion or a custom profile using the EasyTest Control software.

The Actuator mounting apparatus has been designed to integrate to the existing Load Frame. The actuator should only be operated at full capacity only after it has been secured to the load frame using the mounting holes on the base flange.

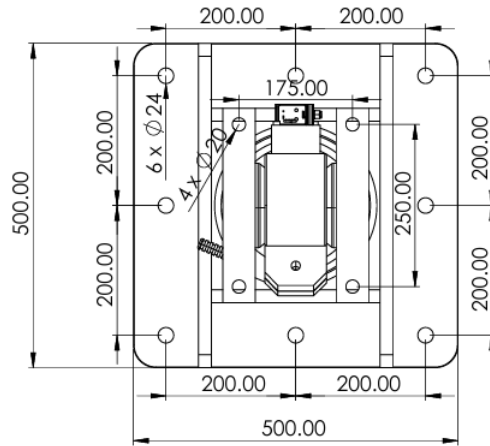
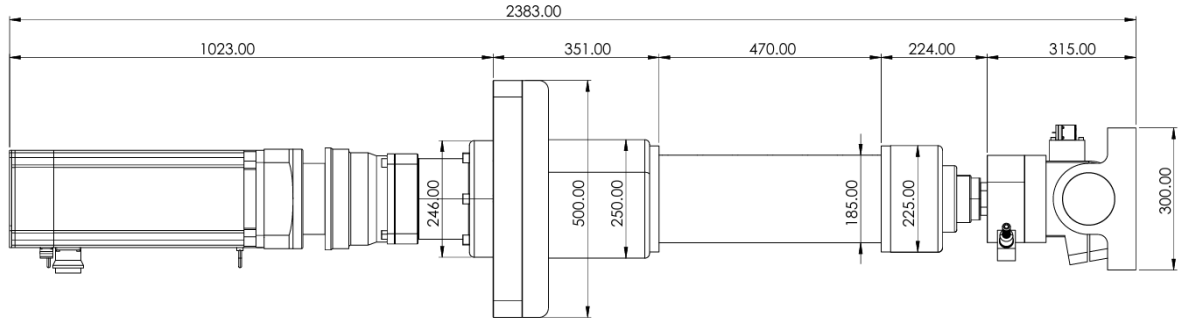

## 1.2 Control Box

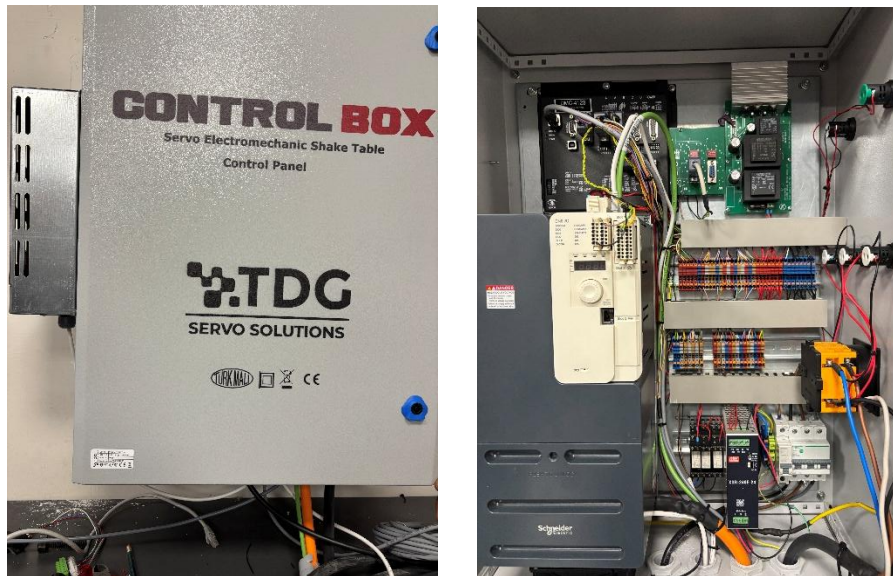

The Actuator comes with a Control box which can be fixed to the wall or to a floor.

The Control box is a 2 axis Controller and has connections to read Encoder data from the servo motor, provide power to the motor from the servo drive, read and control Digital Inputs and Outputs, configure the Laser sensor and read Analog output from the loadcell. It is connected to the computer using an Ethernet cable before using the control software. It should be connected to a Single Ph, 110V AC, 50/60Hz Power Supply. Additionally, it also needs to be connected to a 3Ph, 400-480V AC Power Supply to provide power to the servo drive.

All necessary cables and connections have been provided with the Actuator and no additional cables/connections are required to operate the device. The Connection Schematics diagram below shows all the necessary connections between the actuator and the Control box.

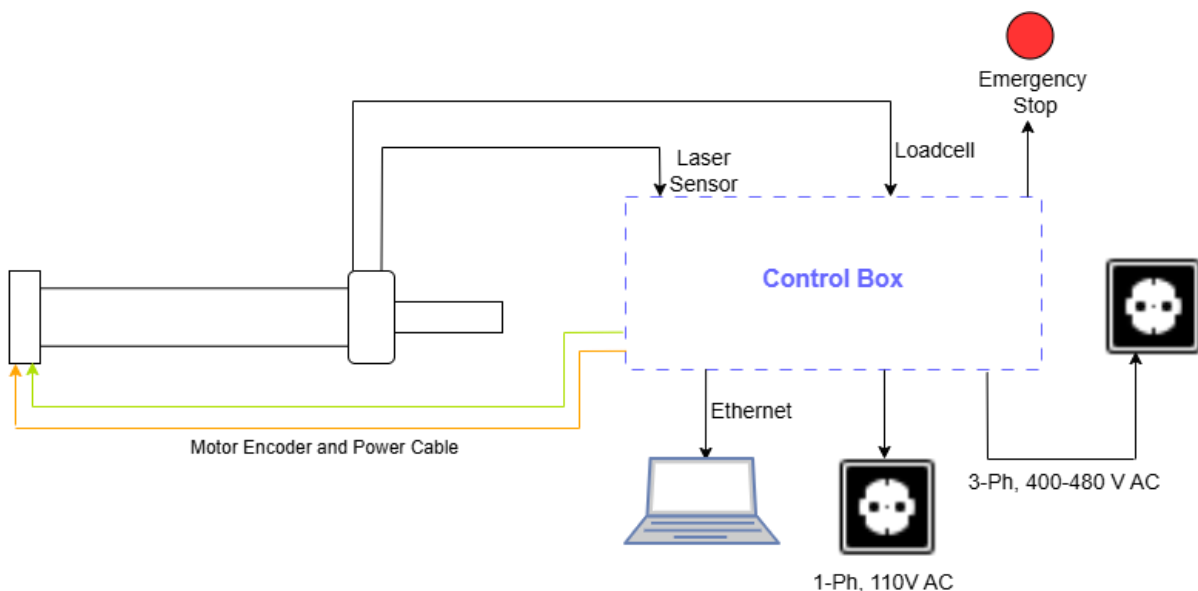

## 2 Specifications and Startup

<i>TECHNICAL SPECIFICATIONS</i>	
Input Voltage (for Servo drive)	400-480V AC, 3 Phase 50-60 Hz
Required Line Current	23.3 A at 480V
Max Fuse to be connected upstream	63A
Input Voltage (for Control Box)	110V AC Single Phase 60Hz
Actuator Dimensions	2383x 500 x 500 mm (L x W x H)
Force Capacity	267kN / 60 Kips
Stroke	± 150 mm (300 mm)
Continuous Velocity @ Full Force	25 mm/s
Maximum Velocity	25 mm/s
Position Encoder Resolution	12 Bit
Controller	Closed Loop PID Controller
Position Feedback	Quadrature Encoder



**NOTE:** The Actuator is delivered with all electrical connections secured. When using the Actuator for the first time, please ensure there are no loose connections/wirings in the Control Box and the Actuator Drive.

1. Make sure all cables and connectors are plugged in as per the Connection Schematics in the Installation Manual before operating the Actuator.
2. Check the Emergency Stop Button on the Control Box and turn it to the off position.
3. Turn the device power switch to “ON” position for the Control Box. The power switch for the Wall-mounted Control Box can be found inside the box.
4. Make sure the device power LEDs are active. The three white LEDs and the green LED should light up when the power is turned on. Please contact TDG if any different scenario is observed.
5. Connect a standard Ethernet cable to your computer from the Control Box and turn the power ON.
6. Follow the procedure outlined for EasyTest Control software.

## 3 Test Duration and Test Type

The Actuator is designed for long-duration static tests which can be applied for a couple of minutes at low speeds (up to 25mm/s). For tests with a dynamic nature with varying speeds up to 25mm/s, the force requirement increases and decreases rapidly in a dynamic manner which can also be handled by the system.

Long duration tests and tests which require the device to operate at high forces for a long time causes heating in the system, although the system is designed for high heat protection. When the temperature of the motor and the drive system reaches a certain temperature, the system stops motion.

As a general practice, usage times should not exceed 1-2 minutes for dynamic tests and there should be at least a 2 min break between successive tests (this time can naturally be used to examine graphs and data of the test results). This will extend the service life of the system and will also reduce the possibility of the test being interrupted due to heating.

Please ensure that tests are performed up to 25mm/s speed and 60 Kips Force. It is strongly recommended to set force and position limits through the software. Exerting the actuator to higher forces will permanently damage the system.

Although the Actuator stroke is 300mm, the laser sensor has been configured to allow a working stroke of 275mm for safe operation. If required, this configuration can be changed to extend/limit the working stroke.

## 4 Maintenance of the System

### 4.1 Nuts and Bolts

Bolts and nuts of some components can become loose due to vibrations and fatigue during testing. In particular, the tightness of the following bolts on the actuator should be checked every 3 months or 50 hours of use.

Swivel – Specimen connection	4 x M20
Laser Position sensor	2 x M6 , 2 x M4
Loadcell	8 x M12
Actuator Piston body	7 x M8
Base Flange / Load Frame connection	8 x M22 Bolts
Motor and Gearhead body	6 x M14
Gearhead	4 x M12
Motor	4 x M12

Moreover, any additional bolts on the actuator which can be visibly seen should be inspected at regular intervals.

### 4.2 Dust and Cleaning

Dust can accumulate on the device due to the laboratory environment. Test samples and the Actuator should be cleaned at regular intervals (specially the laser sensor) in order not to affect the life and healthy operation of the device.

A threaded hole plug can be installed in the unused holes on the actuator side to prevent dust from entering the device. When not in use, the actuator can be covered to protect from the dust and environment.

- Clean all the system with a compressor and moist cloth.
- Do not apply excessive amounts of detergent cleaner. It may seep into electrical circuits and cause equipment failure.
- Use low pressure air to blow dust. Do not direct the air stream directly at sensitive components, for instance, servo valve.
- It is recommended that the components be cleaned weekly or more often if they are operating in a dusty or dirty environment.

### 4.3 Maintenance checks before operation

Before operating the system each time, ensure that:

- All cable connections are tight and secure.
- All components including motor, gearhead, laser sensor and actuator body and accessories are free of dirt, damage and deformation.
- Signal cables of Motor, laser sensor, loadcells and other sensors (if any) have adequate slack to prevent excessive strain on connectors.
- All cables are free of wear and chafing. Re-route the cables if necessary and replace any damaged cables.

- After turning on the system, make sure that power is adequately supplied to the electronics (3Ph and 1Ph LED on Control Box should be visibly on).

#### 4.4 Periodic Maintenance

Every 6-12 months, the following inspection and maintenance procedure should be performed:

- Visually check the electrical cable connections for any loose fittings.
- Check bolt connections for Actuator listed in section 4.1. Tighten any loose connections if found.
- Operate the Actuator in position mode through the full range of motion starting from a slow speed and increasing speed at small intervals. The actuator should move smoothly with no unusual noise or erratic motion.
- Check that the Emergency stop buttons are working as expected. If you have any additional safety equipment added to the machine, test the equipment to ensure it is in working order.
- If you notice any problems resulting from these inspections, contact TDG’s Service Department for assistance.

### 5 Troubleshooting

Problem	Action
Software cannot connect to the controller	<ul style="list-style-type: none"> <li>-Make sure the Control Box is powered up and connected to the computer with Ethernet cable.</li> <li>-If any network device is used for the connection (switch, router, external devices, etc.) make sure they are powered up and running properly.</li> <li>-Check that the Ethernet cable is working properly</li> <li>-Make sure the Control Box is receiving 3Ph and 1Ph power properly, by checking the led indicators.</li> <li>-Make sure all the emergency buttons on the system are released.</li> </ul>
The actuator is not responding to position command	<ul style="list-style-type: none"> <li>-Make sure that actuator is not at the stroke limit and the position command is not against the stroke limit.</li> <li>-Make sure that the speed and stroke limits are set properly in the software.</li> <li>-Make sure all the emergency buttons on the system are released.</li> </ul>
The actuator is drifting to one side during stationary condition.	<ul style="list-style-type: none"> <li>-Check that the “Stationary Output Limit” parameter is set to a sufficient value on the software.</li> </ul>
Software has lost connection to the controller.	<ul style="list-style-type: none"> <li>-Close and restart the Easy Test Control software (this may cause the system to disable the servo</li> </ul>

	enable torque. You can enable it after restarting the software)
Motor stopped working during operation.	<p>-Disable the torque, close the software and cut off power to the Control Box.</p> <p>-Wait for several minutes in case there's a heating problem, then check that the cabling and connections are intact at the Control Box and the actuator.</p> <p>-Check the Control Box panel to see if the main circuit breaker switch is down.</p> <p>-Check for any error codes on the Servo Drive screen (anything other than 'RUN' or 'RDY')</p> <p>-If the system fails to start again, contact the manufacturer or maintenance team for further investigation.</p>