

EE451

Wall Mounted Temperature Sensor for Indoor and Outdoor

The EE451 wall mounted sensor measures reliably the temperature (T) indoors and outdoors, is optimized for building automation, HVAC, process control and enables weather-dependent temperature regulation.

Analogue, Digital and Passive Outputs

The T measured data is available on the voltage or current output, as well as on the RS485 interface with Modbus RTU or BACnet MS/TP protocol. In addition, EE451 features a wide choice of sensing elements for passive T measurement.

Easy Installation

The compact and robust enclosure allows for easy and fast installation and unbiased detection of ambient temperature.

Configurable and Adjustable

An optional adapter and the free EE-PC Product Configuration Software facilitate the setup and adjustment of the EE451.

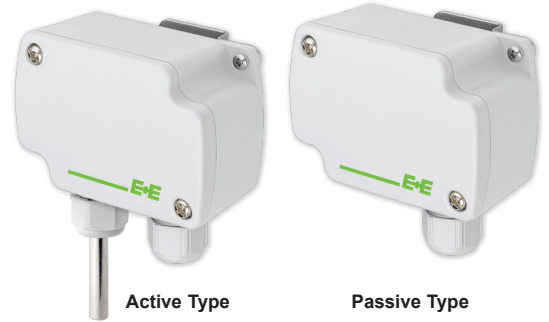

Features



External mounting holes

- » Mounting with closed cover
- » Protection against construction site pollution

Bayonet screws

- » Open/closed with a ¼ rotation

IP65 / NEMA 4

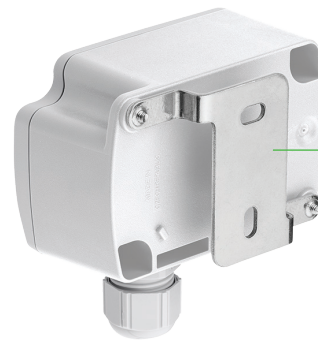

Mounting bracket

- » Distance to wall for correct measurement of ambient temperature

Test report according to
 DIN EN 10204 – 2.2



Technical Data

Active Output

Sensing element	Pt1000 class A, DIN EN60751		
Analogue output	0-10 V	-1 mA I_L <math>< 1</math> mA	
	4-20 mA (two-wire)	$R_L < 500 \Omega$	$R_L =$ load resistance
Digital interface	RS485 with max. 32 unit load devices on one bus		
Protocol	Modbus RTU or BACnet MS/TP		
Accuracy	$\pm 0.3 \text{ }^\circ\text{C}$ ($\pm 0.54 \text{ }^\circ\text{F}$) at $20 \text{ }^\circ\text{C}$ ($68 \text{ }^\circ\text{F}$)		
Supply voltage (Class III)	15-35 V DC or 24 V AC $\pm 20\%$	for RS485 and 0-10 V output	
	10 V DC + $R_L \times 20 \text{ mA} < V+ < 35 \text{ V DC}$	for 4-20 mA output	
Current demand (typ.) analogue	5 mA (DC) / 12 mA _{eff} (AC)		
RS485	3.5 mA (DC) / 12 mA _{eff} (AC)		
Electromagnetic compatibility	EN61326-1, EN61326-2-3 industrial environment		

Passive Output

T sensing elements	Sensor Type	Nominal Resistance	Sensitivity	Standard
	Pt100 DIN B	$R_0: 100 \Omega$	TC: $3.850 \times 10^{-3}/^\circ\text{C}$	DIN EN 60751
	Pt1000 DIN B	$R_0: 1000 \Omega$	TC: $3.850 \times 10^{-3}/^\circ\text{C}$	DIN EN 60751
	NTC1.8k	$R_{25}: 1.8 \text{ k}\Omega \pm 0.2 \text{ K}$	$B_{25/85}: 3500 \text{ K} \pm 1.0 \%$	-
	NTC2.2k	$R_{25}: 2.252 \text{ k}\Omega \pm 0.2 \text{ K}$	$B_{25/85}: 3977 \text{ K} \pm 0.3 \%$	-
	NTC10k B3950	$R_{25}: 10 \text{ k}\Omega \pm 0.5 \%$	$B_{25/85}: 3989 \text{ K}$ ($B_{25/50}: 3950 \text{ K} \pm 1.0 \%$)	-
	NTC10k B3435	$R_{25}: 10 \text{ k}\Omega \pm 1 \%$	$B_{25/85}: 3435 \text{ K}$	-
	KTY81-210	$R_{25}: 1980-2020 \Omega$	-	-
	Ni1000 TK6180 DIN B	$R_0: 1000 \Omega$	TC: 6180 ppm/K	DIN 43760
	Ni1000 TK5000 DIN B	$R_0: 1000 \Omega$	TC: 5000 ppm/K	DIN 43760

Measurement current	typ. < 1 mA (according technical data of the specific T-sensing element)
T-Sensor connection	two-wire

General

Operating temperature	-40...+70 °C (-40...+158 °F)
Enclosure material	polycarbonate, UL94-V0 approved
Protection class	IP65 / NEMA 4
Cable gland	M16x1.5, UL94-V2
Electrical connection	screw terminal, max. 2.5 mm ² (0.004 in ²)
Mounting bracket material	stainless steel (corr. 1.4301 / 304)
Storage temperature	-30...+70 °C (-22...+158 °F)
Working and storage humidity	5...95 % RH, non condensing

Dimensions mm (inch)

Passive output

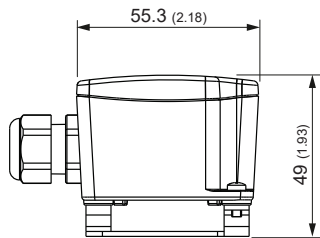
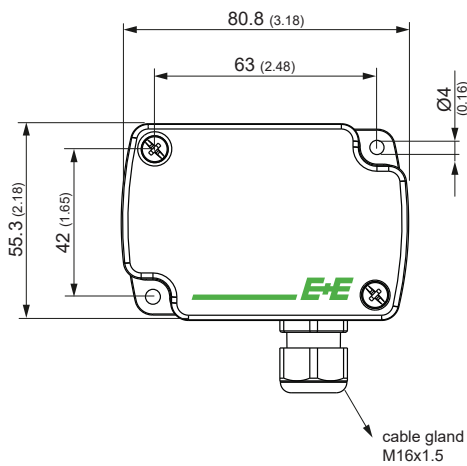

mounting bracket (included in the scope of supply)

Active output

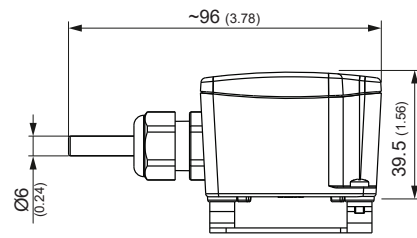
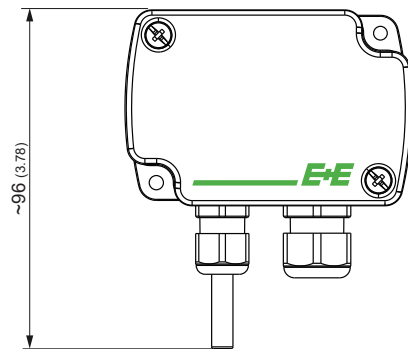

Mounting

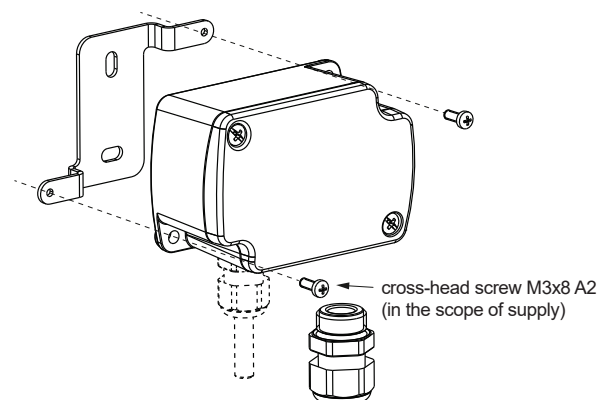

Mounting Bracket

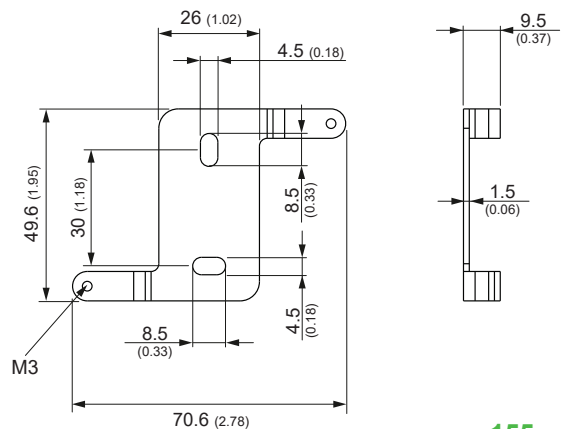

Ordering Guide

		EE451-			
Hardware Configuration	Model	active passive	M3		M7
	Output	0-10 V 4-20 mA RS485	A3 A6	J3	
	T-sensor passive (see www.epluse.com/R-T_Characteristics)	Pt100 DIN B Pt1000 DIN B NTC 1.8k Ni1000, TK6180 DIN B NTC 10k, B3950 KTY81-210 NTC 10k, B3435 Ni1000, TK5000 DIN B NTC 2.2k			TP2 TP4 TP7 TP9 TP11 TP13 TP14 TP19 TP21
Setup Outputs	Unit	°C °F	no code MA2		
	Scale T low	0 value (within working range)	no code SAL value		
	Scale T high	50 value (within working range)	no code SAH value		
	Protocol	Modbus RTU ¹⁾ BACnet MS/TP ²⁾		P1 P3	
	Baud rate	9.600 19.200 38.400 57.600 ³⁾ 76.800 ³⁾		BD5 BD6 BD7 BD8 BD9	

1) Factory setting: Even parity, Stopbits 1. Modbus Map and communication setting: see User Guide and Modbus Application Note at www.epluse.com/ee451

2) Factory setting: No parity, Stopbits 1. Product Implementation Conformance Statement (PICS) available at www.epluse.com/ee451

3) Only for BACnet MS/TP

Order Example

EE451-M3J3P3BD7

Model: active
 Output: RS485
 Protocol: BACnet MS/TP
 Baud rate: 38.400

EE451-M7TP11

Model: passive
 T-sensor passive: NTC 10K, B3950

Accessories

Product configuration adapter

- for analogue output

- for digital output - USB configuration adapter

see data sheet EE-PCA

HA011066

Product configuration software

EE-PCS (free download: www.epluse.com/configurator)

Power supply adapter

V03 (see data sheet Accessories)

Conduit adapter, M16x1.5 to 1/2"

HA011110