

PT01 (MS3111) cable connecting receptacle

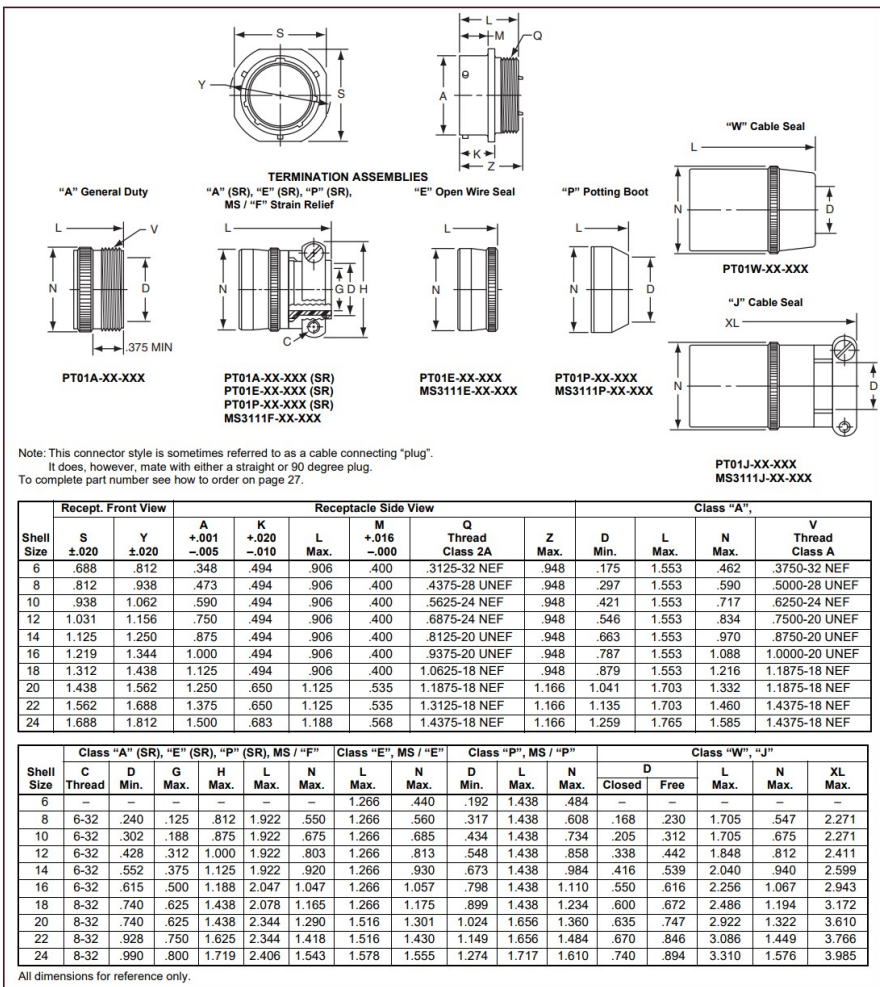

Pin number	Signal
A	+Z
B	-Z
C	+N
D	-N
E	+E
F	-E
G	Power Supply (9V to 20V)
H	RESERVED
J	Ground & Shield
K	Power Supply (0V)